

- Teardrop miniature IEPE Accelerometer
- Shear design
- Piezoelectric ceramic PZT-5
- Sensitivity – 100mV/g
- Mass – 1.2grams
- 6-40 side entry connector
- Adhesive Mount

The UV100S-A is a miniature monoaxial teardrop IEPE accelerometer with a side entry 6-40 microdot connector and a flat base for adhesive mounting. Featuring a shear design PZT-5 sensing element the UV100S-A provides high accuracy with wide bandwidth up to 10kHz

Specification	Metric	Imperial
Sensitivity	10.2mV/(m/s ²)	100mV/g
Measurement Range (pk)	±490m/s ²	±50g
Frequency Range ±10%	1 to 10000 Hz	
Resonant Frequency	≥50 kHz	
Non-Linearity	≤1 %	
Transverse Sensitivity	≤5 %	
Electrical Noise Floor	0.001m/s ² rms	0.0001g rms
Overload Limit (Shock)	±24,500(m/s ²)pk	±2500gpk
Operating Temp. Range	-55 to +125°C	-67 to +257°F
Polarity ↑	Positive	
Compliance Voltage (Supply)	+18 to +28 VDC	
Current range	2 – 10mA	
Output Bias Voltage	11VDC ± 1.5VDC	
Size (excluding connector)	10.95x6.95x5.55 (mm)	0.43x0.27x0.22 (in)
Weight	1.20gm	0.042oz
Sensing Geometry	Shear	
Sensing Element Material	PZT-5	
Case Material	Titanium	
Connector Position	Side	
Case sealing	Hermetic	
Electrical Connection Type	6-40 Microdot	
Mounting	Flat base for adhesive mounting	

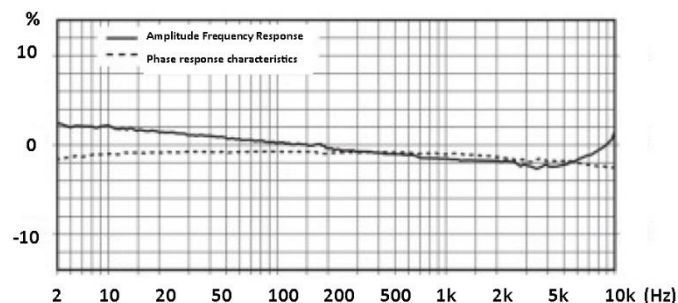
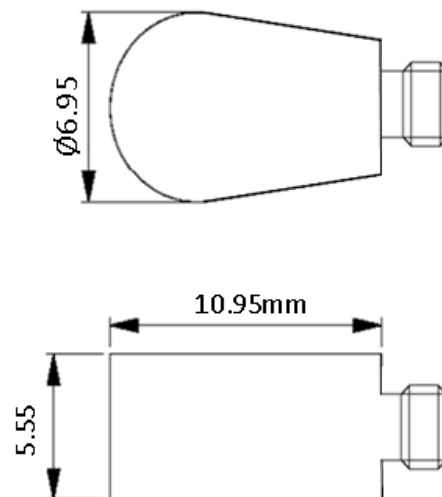

Kemo has a range of cable assemblies available for use with the UV100S-A

- 13E2-30 – 3m(10ft) 6-40 microdot to BNC plug
- 13E2-50 – 5m(15ft) 6-40 microdot to BNC plug
- 13E1-30 – 3m(10ft) 6-40 mdot to 10/32UNFmdot
- 13E1-50 – 5m(15ft) 6-40 mdot to 10/32UNFmdot

Kemo Limited

First Floor, 33 King Street, Theford, Norfolk, IP24 2AW, United Kingdom
+44 (0)1474 705168

www.kemo.com sales@kemo.com