

- Sub Miniature IEPE Accelerometer
- Shear design
- Piezoelectric ceramic PZT-5
- Sensitivity – 100mV/g
- Mass – 2.7grams
- M3.5 side entry connector
- Tapped base mount

The SV100S-T is a sub-miniature monoaxial IEPE accelerometer with a side entry M3.5 miniature microdot connector and a tapped base for stud mounting. Featuring a shear design PZT-5 sensing element the SV100S-T provides high accuracy with wide bandwidth up to 10kHz

Specification	Metric	Imperial
Sensitivity	10.2mV/(m/s ²)	100mV/g
Measurement Range (pk)	±490m/s ²	±50g
Frequency Range ±10%	1 to 10000 Hz	
Resonant Frequency	≥40 kHz	
Non-Linearity	≤1 %	
Transverse Sensitivity	≤5 %	
Electrical Noise Floor	0.001m/s ² rms	0.0001g rms
Overload Limit (Shock)	±49000(m/s ²)pk	±5000gpk
Operating Temp. Range	-55 to +125°C	-67 to +257°F
Polarity ↑	Positive	
Compliance Voltage (Supply)	+18 to +28 VDC	
Current range	2 – 10mA	
Output Bias Voltage	11VDC ± 1.5VDC	
Size (excluding connector)	8.5(A/F)x11 mm	0.33" A/Fx0.43"
Weight	2.7gm	0.096oz
Sensing Geometry	Shear	
Sensing Element Material	PZT-5	
Case Material	Titanium	
Connector Position	Side	
Case sealing	Hermetic	
Electrical Connection Type	M3.5 Miniature Microdot	
Mounting	5-40 tapped base	

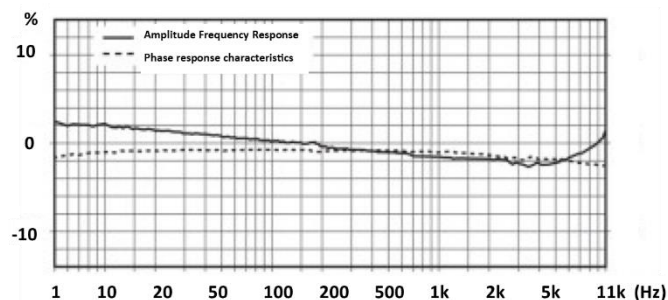
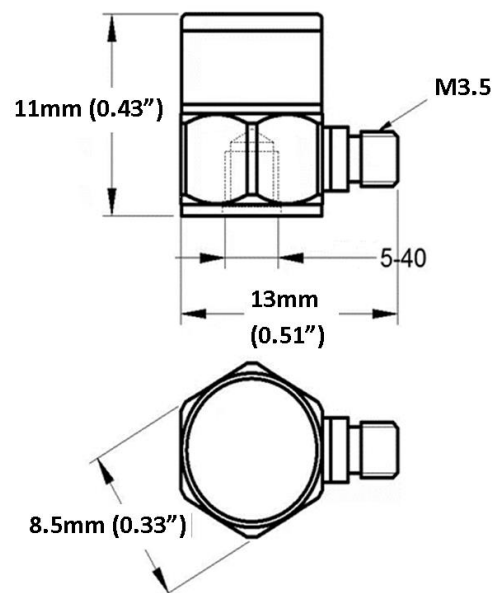

Kemo has a range of cable assemblies available for use with the SV100S-T and other IEPE accelerometers.

13B2-30 – 3m(10ft) M3.5 microdot to BNC plug
 13B2-50 – 5m(15ft) M3.5 microdot to BNC plug
 13B1-30 – 3m(10ft) M3.5 mdot to 10/32UNFmdot
 13B1-50 – 5m(15ft) M3.5 mdot to 10/32UNFmdot

Kemo Limited

First Floor, 33 King Street, Theford, Norfolk, IP24 2AW, United Kingdom
 +44 (0)1474 705168

www.kemo.com sales@kemo.com