

- Triaxial IEPE Accelerometer
- Sensitivity – 10mV/g
- Shear design
- Piezoelectric ceramic PZT-5
- Mass – 8.5grams
- ¼-28UNF side entry 4 pin connector
- Tapped base for stud or adhesive mounting

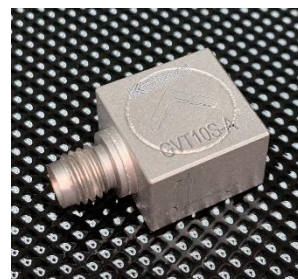

The GVT10S-T is a general purpose triaxial IEPE accelerometer for the measurement of broad band vibration in a wide range of vibration test applications, its small size and low mass make it an ideal all rounder. The tapped base means it can be stud mounted or used with an adhesive base (KMS-ADH1 or KMISO-ADH).

Specification	Metric	Imperial
Sensitivity	1.02mV/(m/s ²)	10mV/g
Measurement Range (pk)	±4900m/s ²	±500g
Frequency Range ±10%	(Z)1 to 8000Hz (X,Y) 1 to 7000Hz	
Resonant Frequency	≥25 kHz	
Non-Linearity	≤1 %	
Transverse Sensitivity	≤5 %	
Electrical Noise Floor	0.01m/s ² rms	0.001g rms
Overload Limit (Shock)	±49000(m/s ²)pk	±5000gpk
Operating Temp. Range	-55 to +125°C	-67 to +257°F
Compliance Voltage (Supply)	+18 to +28 VDC	
Current range	2 – 10mA	
Output Bias Voltage	11VDC ± 1.5VDC	
Size (excluding connector)	15x15x10 (mm)	0.59x0.59x0.39 (in)
Weight	8.5gm	0.30oz
Sensing Geometry	Shear	
Sensing Element Material	PZT-5	
Case Material	Titanium	
Connector Position	Side	
Case sealing	Hermetic	
Electrical Connection Type	¼-28UNF 4 pin	
Mounting	10/32UNF Tapped base for stud or adhesive mounting	

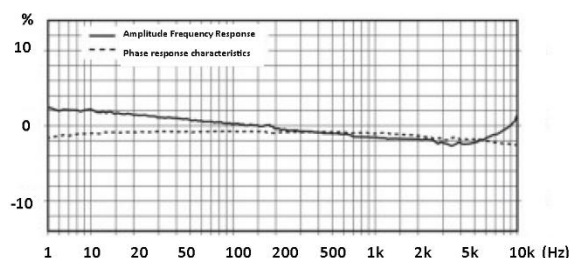
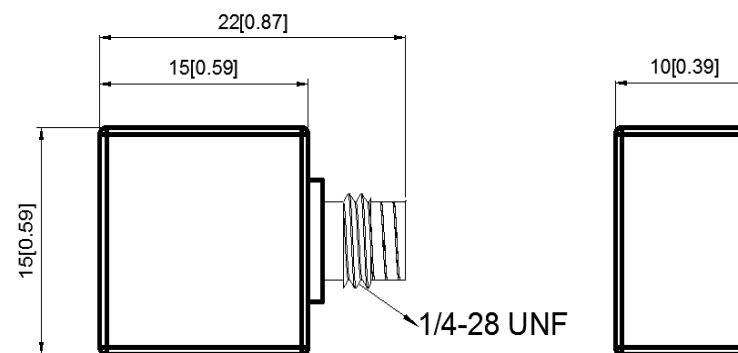

Kemo has a range of cable assemblies available for use with the GVT10S-T

- 7F82-50 – 5m cable ending in 3 x BNC plugs (X, Y, Z)
- 7F82-30 - 3m cable ending in 3 x BNC plugs (X, Y, Z)
- 7F81-50 - 5m cable ending in 3 x microdot plugs (X, Y, Z)
- 7F81-30 - 3m cable ending in 3 x microdot plugs (X, Y, Z)

Kemo Limited

First Floor, 33 King Street, Theford, Norfolk, IP24 2AW, United Kingdom
+44 (0)1474 705168

www.kemo.com sales@kemo.com