

- Teardrop miniature IEPE Accelerometer
- Shear design
- Piezoelectric ceramic PZT-5
- Sensitivity – 5mV/g
- Mass – 0.5grams
- 1m Integral cable
- Adhesive Mount

The UV5S-A is an ultra miniature monoaxial teardrop IEPE accelerometer with a side entry integral cable and a flat base for adhesive mounting. Featuring a shear design PZT-5 sensing element the UV5S-A provides high accuracy with wide bandwidth up to 12kHz.

The extremely small size and low mass means the UV5S-A is almost invisible in terms of mass loading effects.

Specification	Metric	Imperial
Sensitivity	0.51mV/(m/s ²)	5mV/g
Measurement Range (pk)	±9800m/s ²	±1000g
Frequency Range ±10%	0.5 to 12000 Hz	
Resonant Frequency	≥50 kHz	
Non-Linearity	≤1 %	
Transverse Sensitivity	≤5 %	
Electrical Noise Floor	0.02m/s ² rms	0.002g rms
Overload Limit (Shock)	±19,600(m/s ²)pk	±2000gpk
Operating Temp. Range	-55 to +125°C	-67 to +257°F
Polarity ↑	Positive	
Compliance Voltage (Supply)	+18 to +28 VDC	
Current range	2 – 10mA	
Output Bias Voltage	11VDC ± 1.5VDC	
Size (excluding connector)	6x4.1x2.6 (mm)	0.23x0.16x0.10 (in)
Weight	0.5gm	0.017oz
Sensing Geometry	Shear	
Sensing Element Material	PZT-5	
Case Material	Titanium	
Connector Position	Side	
Case sealing	Laser Welded	
Electrical Connection Type	1m Integral cable to 10/32UNF Mdot plug	
Mounting	Flat base for adhesive mounting	

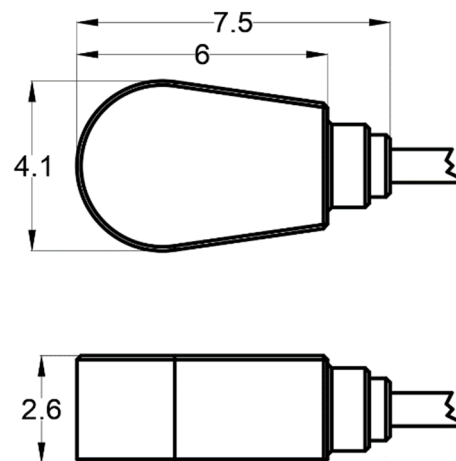

Dimensions in mm

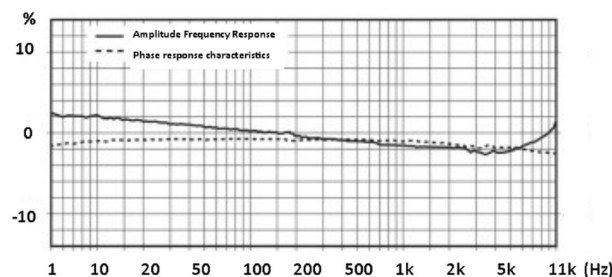
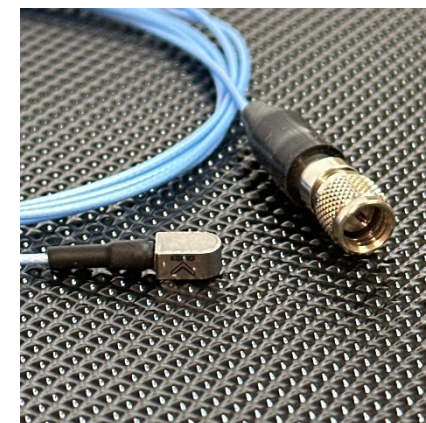

Kemo has a range of extension cable assemblies available for use with the UV5S-A

- 11B2-30 – 3m(10ft) 10/32UNF microdot Skt to BNC plug
- 11B2-50 – 5m(15ft) 10/32UNF microdot Skt to BNC plug
- 11B1-30 – 3m(10ft) 10/32UNF mdot Skt to 10/32UNF mdot plug
- 11B1-50 – 5m(15ft) 10/32UNF mdot Skt to 10/32UNF mdot plug

Kemo Limited

First Floor, 33 King Street, Theford, Norfolk, IP24 2AW, United Kingdom
+44 (0)1474 705168

www.kemo.com sales@kemo.com